USER'S MANUAL (PART 2)

AIR CONDITIONER FOR ELECTRICAL ENCLOSURE OUTDOOR APPLICATION

IP-ACOWM300.432



Document: UMA-CDZ-IP-ACOWM300.432-00		Date	Name
Description Original user's manual for air conditioner IP-ACOWM300.432 series Language: English	ISSUE	26/07/2022	
	REV. 01		
	REV. 02		
	REV. 03		



WARNING

- Safety of AIR CONDITIONER is warranted only by proper use of these instruction which must be kept.
- Installation must be done by qualified personnel only after enclosure power supply disconnecting.
- Before any operation, switch off the power supply.
- The appliance is classified as not accessible to the general public
- The air conditioner is not to be used by persons (including children) with reduced physical, sensory or mental capabilities, or lack of experience and knowledge, unless they have been given supervision or instruction.
- Children being supervised not to play with the air conditioner.
- The air conditioner must be installed in accordance with national wiring regulations (IEC 60335-2-40:2018)
- Upstream of the electrical connection, an efficient disconnection system must be provided in compliance with the AS / NSZ 3000 standard
- Internal and external components of electrical enclosure don't have to affect the proper installation of air conditioner.
- Inside of electrical enclosure there must not be components that could affect the proper ventilation.
- Provide a proper fixing of the electrical enclosure to the floor to prevent accidental tipping due to the supplementary weight of installed AIR CONDITIONER.
- Installation position of AIR CONDITIONER must be selected to ensure good ventilation. Take care that any internal/external components of enclosure don't obstruct air passage. (see section 2.2 GENERAL CHECKS BEFORE INSTALLATION)
- The heat loss of the components installed inside of the electrical enclosure must be lower than useful cooling power of the AIR CONDITIONER.
- AIR CONDITIONER IP-ACIW series must be handled in upright position and protected against accidental tipping over.
- Do not modify the AIR CONDITIONER structure if it is not specified in these instruction or associated instructions.
- During transportation of enclosures with installed air conditioner a proper bracket must be used to support the cooling unit weight.
- Install only original spare parts and accessories.
- Protection against access to live parts must be warranty by installer.
- The supply connector of the AIR CONDITIONER must only be connected and disconnected when electrical enclosure is electrically disconnected.
- Follow all technical data shown in this manual

TABLE OF CONTENTS

WARNING	3
1 - TECHNICAL DATA.....	4
2 - INSTALLATION	5
2.1 PRODUCT HANDLING.....	5
2.2 GENERAL CHECKS BEFORE INSTALLATION	5
2.3 FITTING	6
3 - ELECTRICAL CONNECTION.....	8
3.1 WIRING DIAGRAM.....	8
3.2 ELECTRICAL INSTALLATION	9
3.3 ALARM OUTPUT / DIGITAL INPUT	11
4 – STARTING AND ADJUSTMENT	11
4.1 GENERAL DESCRIPTION.....	11
4.2 DIGITAL THERMOSTAT INSTRUCTION.....	12
5 – SPARE PARTS LIST	17
WARRANTY.....	18
UE DECLARATION OF CONFORMITY.....	19
SAA CERTIFICATE.....	20

1 - TECHNICAL DATA

CONTROL TYPE			ARTICLE CODE
Digital thermostat with alarms			IP-ACOWM300.432
FEATURES		Unit	
Power supply		V ph Hz	400 3 50 / 460 3 60
Cooling capacity EN14511	A35-A35	W	2800/2940
	A35-A50	W	2130/2320
Absorbed electric power EN14511	A35-A35	W	2090/2200
	A35-A50	W	2400/2550
Rated current		A	2.2 / 2.6
Motor circuit breaker / Delayed pre fuse (advised)		A	16
Electrical connection		-	connector
Air flow rate (free blow)	enclosure	m3/h	860/950
Operating temperature	ambient	°C (°F)	+5 +55 (+41 + 131) / +5 +50 (+41 + 122)
	enclosure	°C (°F)	+20 +45 (+68 / + 113)
Refrigerant		- g	R134a 1000
Protection degree EN60529/1	ambient	-	IP34
	enclosure	-	IP54 (when installed on enclosure with the same protection degree)
Design	casing	-	Galvanised sheet steel
	cover	-	Galvanised sheet steel powder coated RAL7035
Weight		kg	76
Conformity / Certifications		-	CE, SAA 203165

2 - INSTALLATION

2.1 PRODUCT HANDLING



AIR CONDITIONER IP-ACOW series must be handled in upright position and protected against accidental tipping over.

Air conditioners IP-ACOW series are fitted with female blind threaded insert to screw male lifting eye bolts (included).

The air conditioner handling, when unpacked, can be done thanks to lifting eye bolt. If lifting eye bolts are not included, please provide an adequate M6 male lifting eye bolt (2) and screw it inside blind threaded (1) insert placed on top of the air conditioner



Check the proper fixing of eye bolts before lift the air conditioner.

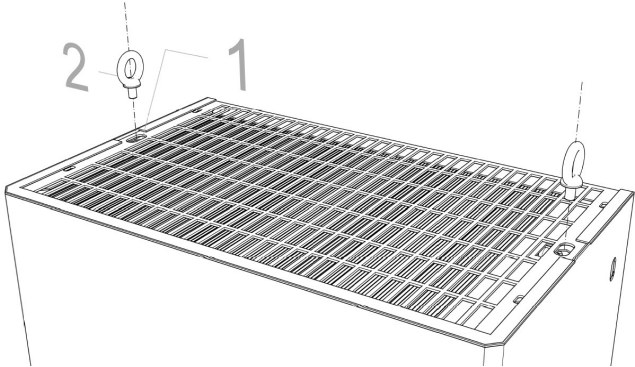

2.2 GENERAL CHECKS BEFORE INSTALLATION



Before the installation make sure that the cabinet is disconnected from the electrical supply.

GENERAL CHECKS
- electrical enclosure must be disconnected form power supply
- electrical data shown on rating label pasted on air conditioner side must be guaranteed
- Electrical enclosure must be sized according to air conditioner dimensions and weight.
- Electrical enclosure must have at least IP54 protection degree
- Internal and external components of electrical enclosure don't have to affect the proper installation of air conditioner
- The installation site must be free from excessive dirt, aggressive ambient conditions and moisture.
- The installation site must be free from hot air flows
- The internal side of electrical enclosure must be free from dirt and moisture
- The environment temperature must be within the range specified on label pasted on air conditioner side
- Inside of electrical enclosure there must not be components that could affect the proper ventilation
- the enclosure positioning with installed air conditioner must be carefully selected to ensure good ventilation (clearance between the air conditioner and the near walls must be at least 500 mm in each side).
- Proper disposing of condensate discharge

2.3 FITTING

1) Make the fixing hole on the enclosure as is shown in the drilling template

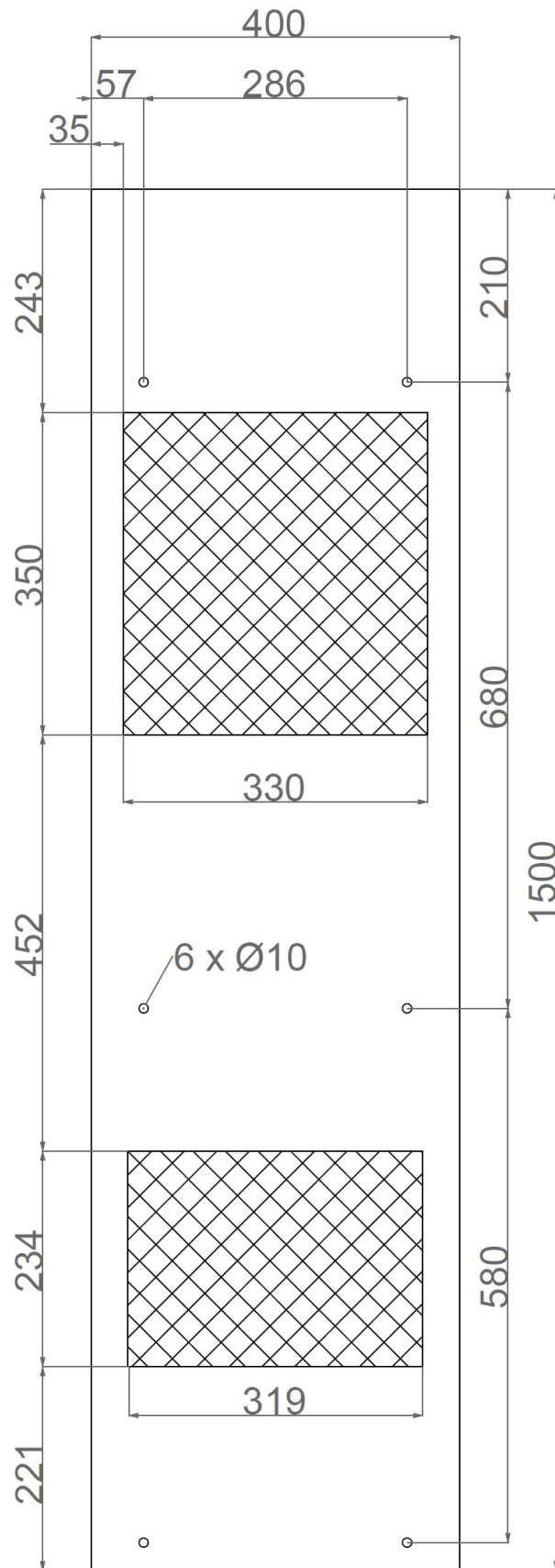

Deburr all sharp edges to avoid accidental injuries

2) Apply the gasket (included in fixing kit) on the back panel of the air conditioner.

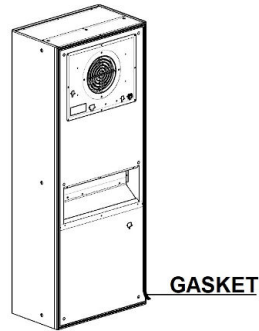

3) Lift the air conditioner by lifting eyebolt and place it near the enclosure wall

4) Mount the air conditioner on the electrical cabinet according to the drilling template with M6X16 screws and washers against unscrewing (included in mounting kit)

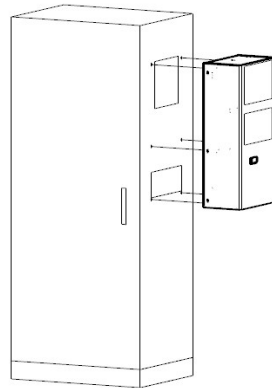

5) Connect the condensate drain pipe like is shown in picture below.

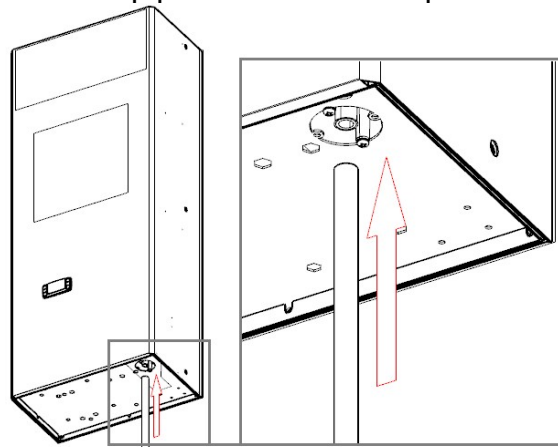

Air conditioner is fitted with condensate evaporator. Condensate is collected into a vessel and it is warmed by the hot discharge compressor pipe. If condensate rises over a certain level, it is evacuated by over flow pipe



Air conditioner produces condensate because the moist air inside of the enclosure meets cold heat exchanger (evaporator) and then it becomes water; water production decreases during air conditioner working because enclosure air becomes dry.



The enclosure must be IP 54 protected, if enclosure is not airtight, condensate production could increase.



The enclosure IP54 degree is guaranteed only if the air conditioner is proper mounted.

3 - ELECTRICAL CONNECTION

3.1 WIRING DIAGRAM

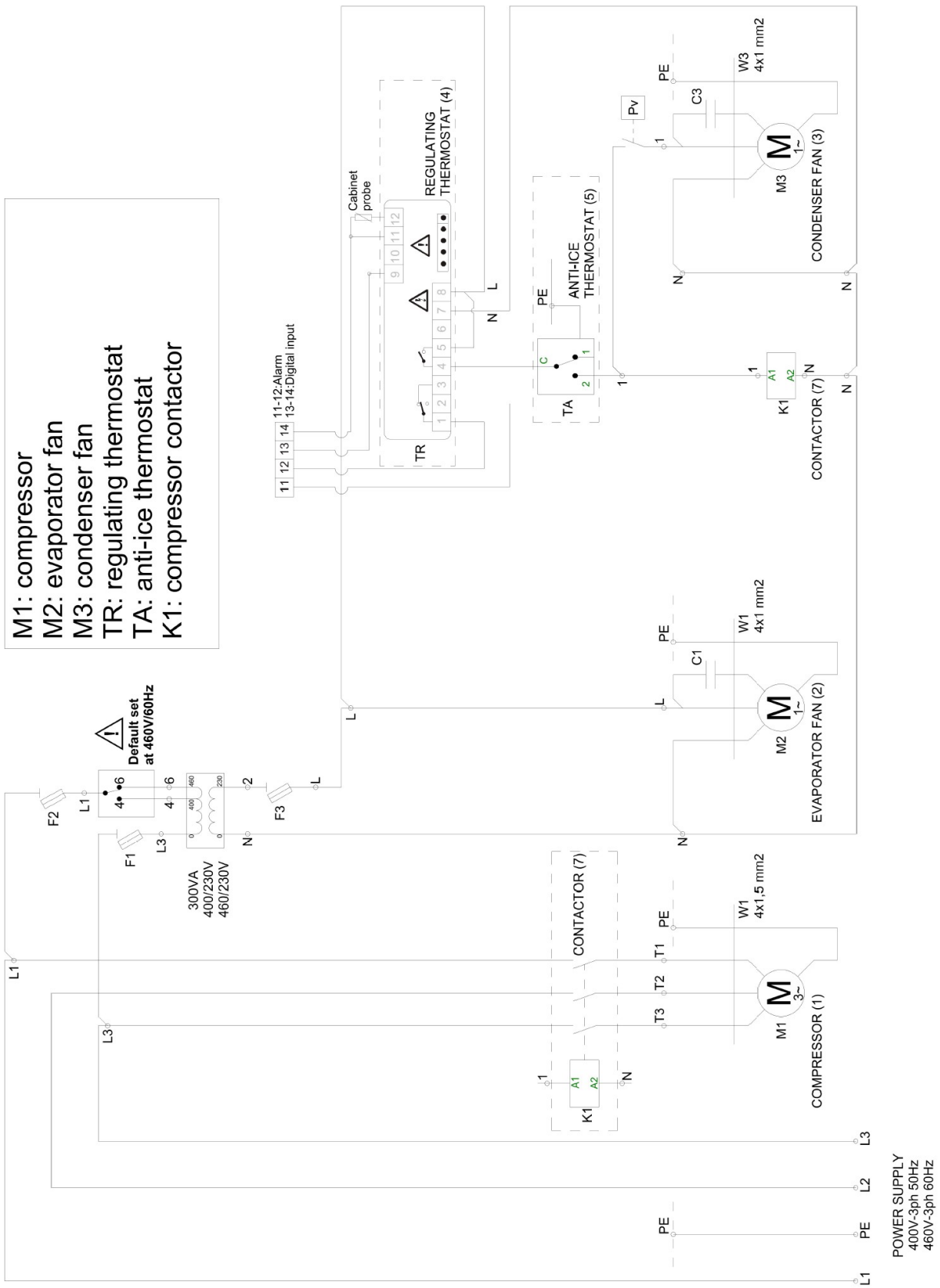

3.2 ELECTRICAL INSTALLATION



The electrical installation must be carried out by a qualified electrician who is responsible for compliance with the applicable standards and regulations.



Electrical data shown on rating label pasted on air conditioner side must be guaranteed



Install the delayed fuse recommended on rating plate pasted on air conditioner side to protect the line and enclosure components against short-circuit.



Upstream of the electrical connection, an efficient disconnection system must be provided and it must be clearly identified



Air conditioner is already fitted with a temperature controller, no additional temperature control must be connected upstream of the unit.



Air conditioner is factory wired for 460VAC input voltage, if needed it can be changed at 400VAC. Select the proper wiring according to mains voltage where unit is installed.



Input voltage selection can be carried out by male connector proper wiring. Supply male connector is included in mounting kit and it is factory wired as is shown in picture below.

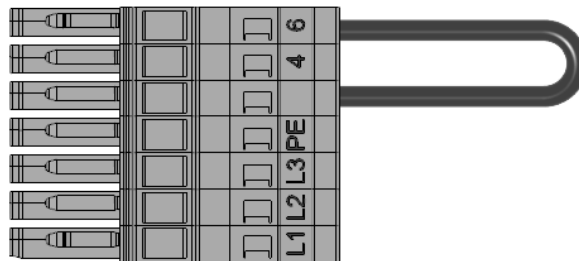

- Bridge from blank pole to pole 6 means input voltage set at 460VAC
- In case of mains voltage at 400VAC the bridge must be shifted from pole 6 to pole 4
- After supply voltage selection, male connector can be wired with main cable.



Before the installation make sure that the cabinet is disconnected from the electrical supply.

Wire male plug with an adequate cable as is shown by picture, phases order shown on male connector must be kept



Cable section must be at least 1,5mm²

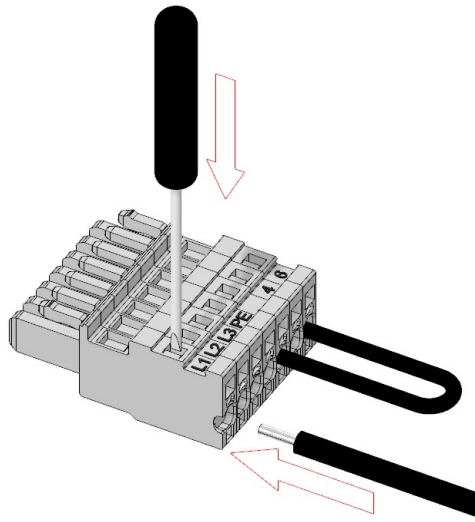

The male plug is fitted with spring terminals:

- 1.1) Push the spring with a screwdriver and then insert the wire.
- 1.2) Check the proper wire insertion.
- 1.3) Insert male connector inside of 7 poles female connector placed on the back of the air conditioner.



When air conditioner is installed on electrical enclosure, female connector is accessible only from inside the enclosure.

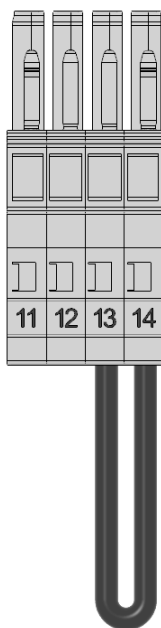
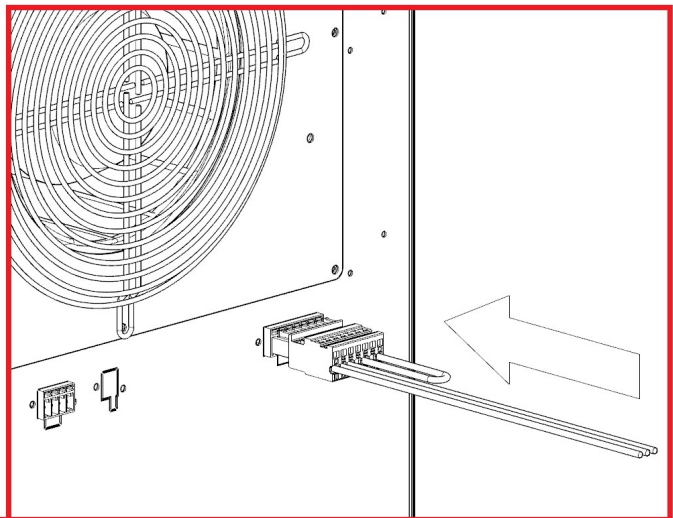
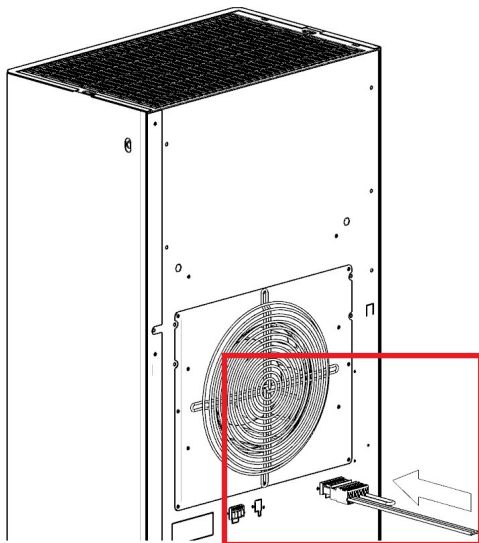

- 1.4) Insert signal connector (included in installation kit, refer to picture below) inside of 4 poles female connector placed on the back of the air conditioner.

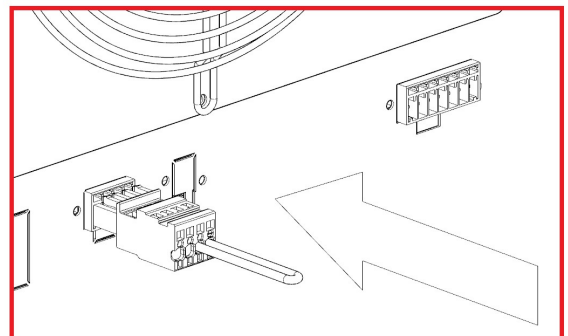
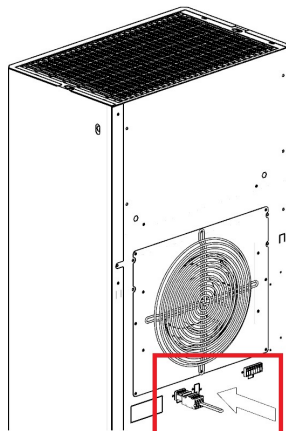

3.3 ALARM OUTPUT / DIGITAL INPUT

Air conditioner is fitted with an electronic controller which permits alarm output and digital input signals.

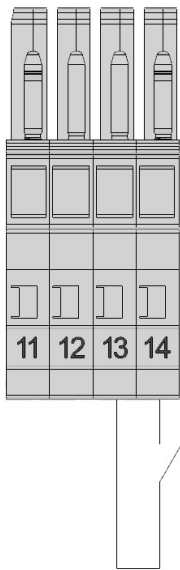

3.3.1 Alarm output

Alarm output is activated according to alarm parameters (for example in case of enclosure temperature higher than ALU value, digital input not activated... See PARAMETERS at 4.2 DIGITAL THERMOSTAT INSTRUCTION section)

Alarm output is a dry contact.

3.3.2 Digital input

WARNING: proper functions of air conditioner are allowed only if digital input is activated. (closed contact between poles 13-14).

Digital input can be a door limit switch or a generic external dry contact.



Plug for signals is factory wired with a bridge between 13-14 poles. Bridge can be removed to wire, for example, a door limit switch.

Connect signal plug with signal female connector placed on the back of the air conditioner, near of power supply connector.

4 – STARTING AND ADJUSTMENT

4.1 GENERAL DESCRIPTION

IP-ENCLOSURES air conditioners are especially designed for dissipation of heat loss inside electrical enclosures with IP54 protection degree.

Air circulation inside the enclosures allows to keep enclosure air volume isolated from external ambient air, it preserves the inside of the enclosure against dirt and humidity which are present in the external air.



IP-ACIW series must be installed only on the wall of electrical enclosure



After air conditioner assembly, wait approx. 30 min. before starting it (the oil must collect in the compressor to ensure lubrication and cooling).

The air conditioner operates automatically, that is to say, after insertion, the evaporator fan operates continuously making the air inside the cabinet circulate. This way a uniform distribution of temperature inside the cabinet itself is attained. The built-in thermostat drives compressor and condenser fan according to set point value and other parameters (See PARAMETERS at **4.2 DIGITAL THERMOSTAT INSTRUCTION** section for references)

Compressor and condenser fan start after a delay set on thermostat (see parameter AC on parameters list for references) to permit a minimum interval between the compressor stop and the following restart.



During proper operations, the compressor and condenser fan turn OFF when internal enclosure temperature decreases under set point value.





4.2 DIGITAL THERMOSTAT INSTRUCTION





WARNING: the air conditioner is designed to operate at 35 ° C cabinet temperature. If the set point is changed the performance of the unit will vary.

- 1) Regulating thermostat is fixed on side of air conditioner.
- 2) Thermostat could be set into a range from 20°C up to 50°C. Follow thermostat instructions for parameter changing.









SET	To display target set point; in programming mode it selects a parameter or confirm an operation.
	(DEF) To start a manual defrost
	To see the max. stored temperature; in programming mode it browses the parameter codes or increases the displayed value.
	To see the min stored temperature; in programming mode it browses the parameter codes or decreases the displayed value.
	To switch the instrument off, if onF = oFF.
	To switch the light, if oA1 = Lig

4.2.1 KEY COMBINATIONS:

	To lock & unlock the keyboard.
	To enter in programming mode
	To return to the room temperature display

4.2.2 LED FUNCTION DESCRIPTION:

LED	MODE	FUNCTION
	ON	Compressor enabled
	Flashing	Anti-short cycle delay enabled
	ON	Defrost enabled
	ON	An alarm is occurring
	ON	Continuous cycle is running
	ON	Energy saving enabled
	ON	Light on
AUX	ON	Auxiliary relay on
°C/°F	ON	Measurement unit
°C/°F	Flashing	Programming phase

4.2.3 MAX & MIN TEMPERATURE MEMORIZATION

How to see the min temperature

1. Press and release the ▼ key.
2. The “Lo” message will be displayed followed by the minimum temperature recorded.
3. By pressing the ▼ key again or by waiting 5s the normal display will be restored.

How to see the max temperature

1. Press and release the ▲ key.
2. The “Hi” message will be displayed followed by the maximum temperature recorded.
3. By pressing the ▼ key again or by waiting 5s the normal display will be restored.

How to reset the max and min temperature recorded

1. Hold press the **SET** key for more than 3s, while the max. or min temperature is displayed. (**rSt** message will be displayed)
2. To confirm the operation the “**rSt**” message starts blinking and the normal temperature will be displayed.

4.2.4 HOW TO SEE THE SET POINT

1. Push and immediately release the **SET** key: the display will show the Set point value;
2. Push and immediately release the **SET** key or wait for 5 seconds to display the probe value again.

4.2.5 HOW TO CHANGE THE SETPOINT

1. Push the **SET** key for more than 2 seconds to change the Set point value;
2. The value of the set point will be displayed and the “°C” or “°F” LED starts blinking;
3. To change the Set value push the ▲ or ▼ arrows within 10s.
4. To memorise the new set point value push the **SET** key again or wait 10s.

4.2.6 HOW TO CHANGE A PARAMETER VALUE

To change the parameter's value operate as follows:

1. Enter the Programming mode by pressing the **SET + ▼** keys for 3s (the “°C” or “°F” LED starts blinking).
2. Select the required parameter. Press the **SET** key to display its value
3. Use **▲** or **▼** to change its value.
4. Press **SET** to store the new value and move to the following parameter.

To exit: Press **SET + ▲** or wait 15s without pressing a key.

NOTE: the set value is stored even when the procedure is exited by waiting the time-out to expire.

4.2.7 HOW TO LOCK THE KEYBOARD

1. Keep pressed for more than 3 s the **▲ + ▼** keys.
2. The **POF** message will be displayed and the keyboard will be locked. At this point it will be possible only to see the set point or the MAX o Min temperature stored
3. If a key is pressed more than 3s the **POF** message will be displayed.

4.2.8 HOW TO UNLOCK THE KEYBOARD

Keep pressed together for more than 3s the **▲ + ▼** keys, till the **Pon** message will be displayed.

4.2.9 THE ON/OFF FUNCTION

With **onF = oFF**, pushing the **ON/OFF** key, the instrument is switched off. The **OFF** message is displayed. In this configuration, the regulation is disabled.

To switch the instrument on, push again the **ON/OFF** key.

WARNING: Loads connected to the normally closed contacts of the relays are always supplied and under voltage, even if the instrument is in standby mode.

4.2.10 PARAMETERS

Regulation

- Hy** **Differential:** (0,1 ÷ 25,5°C / 1÷255 °F) Intervention differential for set point.
Compressor
Cut IN is Set Point + differential (Hy). Compressor Cut OUT is when the temperature reaches the set point.
- Ot** **Thermostat probe calibration:** (-12.0÷12.0°C; -120÷120°F) allows to adjust possible offset of the thermostat probe.
- AC** **Anti-short cycle delay:** (0÷50 min) minimum interval between the compressor stop and the following restart.
- CH** **Type of action:** CL = cooling; Ht = heating.
- rES** **Resolution (for °C):** (in = 1°C; dE = 0.1 °C) allows decimal point display.
dLy Display delay: (0 ÷20.0m; risul. 10s) when the temperature increases, the display is updated of 1 °C/1°F after this time.
- IdF** **Interval between defrost cycles:** (0÷120h) Determines the time interval between the beginning of two defrost cycles.

- MdF (Maximum) length for defrost:** (0÷255min) (0=no defrost) When P2P = n, (not evaporator probe: timed defrost) it sets the defrost duration, when P2P = y (defrost end based on temperature) it sets the maximum length for defrost.
- ALU MAXIMUM temperature alarm:** (SET÷110°C; SET÷230°F) when this temperature is reached the alarm is enabled, after the “ALd” delay time.
- ALL Minimum temperature alarm:** (-50.0 ÷ SET°C; -58÷230°F when this temperature is reached the alarm is enabled, after the “ALd” delay time.
- i1P Digital input polarity:** oP: the digital input is activated by opening the contact; CL: the digital input is activated by closing the contact.
- i1F Digital input configuration:** EAL = external alarm: “EA” message is displayed; bAL = serious alarm “CA” message is displayed. PAL = pressure switch alarm, “CA” message is displayed; dor = door switch function; dEF = activation of a defrost cycle; AUS =to switch on the second relay if oA1 = AUS; Htr = kind of action inversion (cooling –heating); FAn = not set it; ES = Energy saving.
- did** (0 ÷ 255 min) with i1F= EAL or i1F = bAL digital input alarm delay: delay between the detection of the external alarm condition and its signalling.
with i1F= dor: door open signalling delay
with i1F = PAL: time for pressure switch function: time interval to calculate the number of the pressure switch activation.
- PbC Type of probe:** it allows to set the kind of probe used by the instrument: PbC = PBC probe, ntc = NTC probe.
- dP3 Third probe display-** no available
- .dP4 Fourth probe display-** no available

4.2.11 DIGITAL INPUT (ENABLED WITH P3P = N)

The free voltage digital input is programmable in different configurations by the “i1F” parameter.

Door switch input (i1f = dor)

It signals the door status and the corresponding relay output status through the **odc** parameter:

no= normal (any change);, **Fan**= fan OFF; **CPr**= Compressor OFF, **F_C**= Compressor and fan OFF.

Since the door is opened, after the delay time set through parameter **did**, the door alarm is enabled, the display shows the message **dA** and the regulation restarts is **rtr = yES**. The alarm stops as soon as the external digital input is disabled again. With the door open, the high and low temperature alarms are disabled.

Digital inputs polarity

The digital input polarity depends on the **i1P** parameter.

i1P=CL: the input is activated by closing the contact.

i1P=OP: the input is activated by opening the contact

4.2.12 GENERIC ALARM (i1F = EAL)

As soon as the alarm input is activated (for example enclosure temperature higher than ALU value) the unit will wait for **did** time delay before signalling the **EAL** alarm message.

The outputs status doesn't change. The alarm stops just after the alarm input is de-activated.

4.3.13 SERIOUS ALARM MODE (i1F = bAL)

When the alarm input is activated (for example enclosure temperature higher than ALU value), the unit will wait for **did** delay before signalling the **CA** alarm message. The relay outputs are switched OFF. The alarm will stop as soon as the alarm input is de-activated.

4.2.14 ALARM SIGNALS

Mess age	Cause	Outputs
"P1"	Room probe failure	Compressor output acc. to par. "Con" and "COF"
"P3"	Third probe failure	Outputs unchanged
"P4"	Fourth probe failure	Outputs unchanged
"HA"	Maximum temperature alarm	Outputs unchanged.
"LA"	Minimum temperature alarm	Outputs unchanged.
"HA2"	Condenser high temperature	It depends on the "Ac2" parameter
"LA2"	Condenser low temperature	It depends on the "bLL" parameter
"dA"	Door open	Compressor according to rrd
"EA"	External alarm	Output unchanged.
"CA"	Serious external alarm (i1F=bAL)	All outputs OFF.
"CA"	Pressure switch alarm (i1F=PAL)	All outputs OFF
"rtc"	Real time clock alarm	Alarm output ON; Other outputs unchanged; Defrosts according to par. "IdF" Set real time clock has to be set
rtF	Real time clock board failure	Alarm output ON; Other outputs unchanged; Defrosts according to par. "IdF" Contact the service

4.2.15 DEFAULT SETTING VALUES

Label	Name	Range	°C/°F	
Set	Set point	LS÷US	31.0	---
Hy	Differential	0,1÷25.5°C/ 1÷ 255°F	4.0	Pr1
Ot	Thermostat probe calibration	-12÷12°C /-120÷120°F	0.0	Pr1
AC	Anti-short cycle delay	0 ÷ 50 min	3	Pr1
CH	Kind of action	CL=cooling; Ht= heating	cL	Pr1
rES	Resolution	in=integer; dE= dec.point	dE	Pr1
IdF	Interval between defrost cycles	1 ÷ 120 hours	8	Pr1
MdF	(Maximum) length for defrost	0 ÷ 255 min	0	Pr1
ALU	MAXIMUM temperature alarm	Set÷ 110.0°C; Set÷230°F	50.0	Pr1
ALL	Minimum temperature alarm	-50.0°C÷Set/ -58°F÷Set	-50.0	Pr1
i1P	Digital input polarity	oP=opening;CL=closing	oP	Pr1
i1F	Digital input configuration	EAL, bAL, PAL, dor; dEF; Htr, AUS	dor	Pr1
did	Digital input alarm delay	0÷255min	0	Pr1
PbC	Kind of probe	Ptc; ntc	ntc	Pr1
dP3	Third probe display	--	noP	Pr1
dP4	Fourth probe display	--	noP	Pr1

5 – SPARE PARTS LIST

REFERRED TO WIRING DIAGRAM	DESCRIPTION	CODE
1	Evaporator fan	VCENT220D230V
2	Compressor	NJ6226ZX
3	Condenser fan	VCENT250D230V
4	Regulating thermostat	TERMDIG1S1D2R
5	Anti-ice safety thermostat	TERM.ALL.COND
7	Compressor contactor	CONTAT9A3P
C1	Evaporator fan capacitor	CON2UFS2M8F
C3	Condenser fan capacitor	CON5UFS2M8F
	Supply connector (male plug)	SPINALIM7
	Signal connector (male plug)	SPIN-SEGN4
Pv	Pressure switch	PRSWO7-C10

WARRANTY

WE
IP ENCLOSURES



guarantees that the product is free from any quality defects.

The product is guaranteed for a period of 12 months from the date of delivery, provided it operates under the following conditions:

1. value of power supply indicated in the data plate is completely respected;
2. requirements specified on user's manual are completely respected;
3. cabinet temperature is not higher or lower than its rated temperature;
4. ambient temperature is not higher or lower than its rated temperature;
5. the product is mounted on cabinets with a minimum IP54 protection level;
6. the product is mounted on cabinets that not requiring higher cooling power than expected;
7. the product is clearly identifiable by serial number.

The warranty does not apply if :

1. the cooling circuit has been modified about type and quantity of refrigerant or composition;
2. the unit operates in acid or corrosive ambient;
3. the unit has been modified without IP ENCLOSURES consent.

This warranty shall become null as soon as the product is altered or modified in its structure or in circuits.

The terms of this warranty (commencement and termination dates) are not modified by any repair or replacement of products.

For every part that results defective during the period of this warranty, IP ENCLOSURES shall repair or replace it. Any others charges arising from removal, handling and installation of the products shall not be refunded by IP ENCLOSURES.

Like is specified on user's manual, installation, handling, the correct earthing in accordance with all current standards are under the responsibility of costumer.

In the event of any damage caused by a defective product shall apply the EEC85.374 standard.

The malfunction must be communicated in writing to IP ENCLOSURES.

Warranty is void if the costumer is not in good standing with the payments

UE DECLARATION OF CONFORMITY



WE
IP ENCLOSURES



DECLARE THAT THE AIR CONDITIONER FOR ELECTRICAL CABINETS

IP-ACOW series

DO COMPLY WITH THE FOLLOWING DIRECTIVES

2006/42/CE MACHINERY DIRECTIVE (17 May 2006)

2014/35/UE LOW VOLTAGE DIRECTIVE (26 February 2014)

2014/30/UE EMC DIRECTIVE (26 February 2014)

2011/65/UE ROHS DIRECTIVE (8 June 2011)

STANDARDS APPLIED TO MEET THE PRINCIPAL ELEMENTS OF THE DIRECTIVE

EN 60335-2-40:2003; A1; A2 (IEC 60335-2-40: 2002; A1; A2)

EN 60335-1: 2010; A11; A13; A14; A1; A2 (IEC 60335-1; A1; A2)

OTHER STANDARDS APPLIED

EN 55014-1: 2017

EN 55014-2: 2015

EN IEC 61000-3-2: 2019

EN 61000-3-3: 2013

		Date	Name
Description Declaration of Conformity for air conditioner IP-ACIW	ISSUE	01/06/2020	
	REV. 1		
	REV. 2		
	REV. 3		

SAA CERTIFICATE



APPROVALS®

Certificate of Suitability

Addendum

Certificate No.: SAA203165

Date of Issue: 6 October 2022

Regulatory Definition: Non-Declared

Product Description: Air-conditioning unit for cabinet

Additional Models	Trade Name	Rating/Marking
IP-ACIWM300.431	IP Enclosures	400/460Vac 50/60Hz Max 2400W R134a/1000g, Max Pressure: 2400kPA Class I, IP34 (External side), IP54 (Internal side)
IP-ACIWM300.432	IP Enclosures	400/460Vac 50/60Hz Max 2400W R134a/1000g, Max Pressure: 2400kPA Class I, IP34 (External side), IP54 (Internal side)
IP-ACOWM300.431	IP Enclosures	400/460Vac 50/60Hz Max 2400W R134a/1000g, Max Pressure: 2400kPA Class I, IP34 (External side), IP54 (Internal side)
IP-ACOWM300.432	IP Enclosures	400/460Vac 50/60Hz Max 2400W R134a/1000g, Max Pressure: 2400kPA Class I, IP34 (External side), IP54 (Internal side)
IP-ACIWM400.431	IP Enclosures	400/460Vac 50/60Hz Max 2600W R134a/1000g, Max Pressure: 2400kPA Class I, IP34 (External side), IP54 (Internal side)
IP-ACIWM400.432	IP Enclosures	400/460Vac 50/60Hz Max 2600W R134a/1000g, Max Pressure: 2400kPA Class I, IP34 (External side), IP54 (Internal side)
IP-ACOWM400.431	IP Enclosures	400/460Vac 50/60Hz Max 2600W R134a/1000g, Max Pressure: 2400kPA Class I, IP34 (External side), IP54 (Internal side)
IP-ACOWM400.432	IP Enclosures	400/460Vac 50/60Hz Max 2600W R134a/1000g, Max Pressure: 2400kPA Class I, IP34 (External side), IP54 (Internal side)

R. A. Hill

For and on Behalf of
SAA Approvals Pty Ltd

SAA Approvals Pty Ltd confirms that the product nominated
in this certificate complies with standard/s listed.

For SAA Contact Details and to verify this Certificate go to:
www.saaapprovals.com.au



Issued: 06-10-22 203165/8