

RevNo	Revision note	Date	Signature	Checked
2	GENERAL REVISION	9/7/19	IP	IP

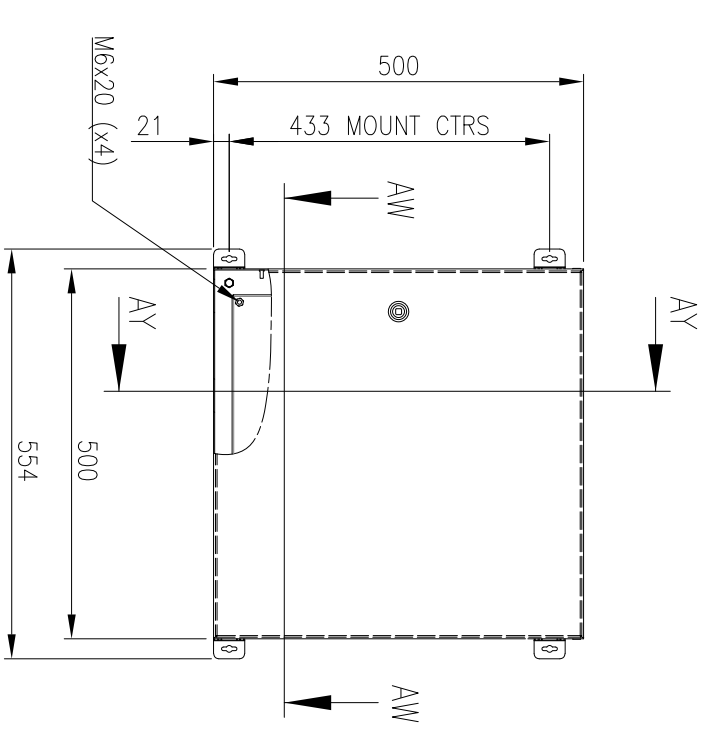

FRONT VIEW

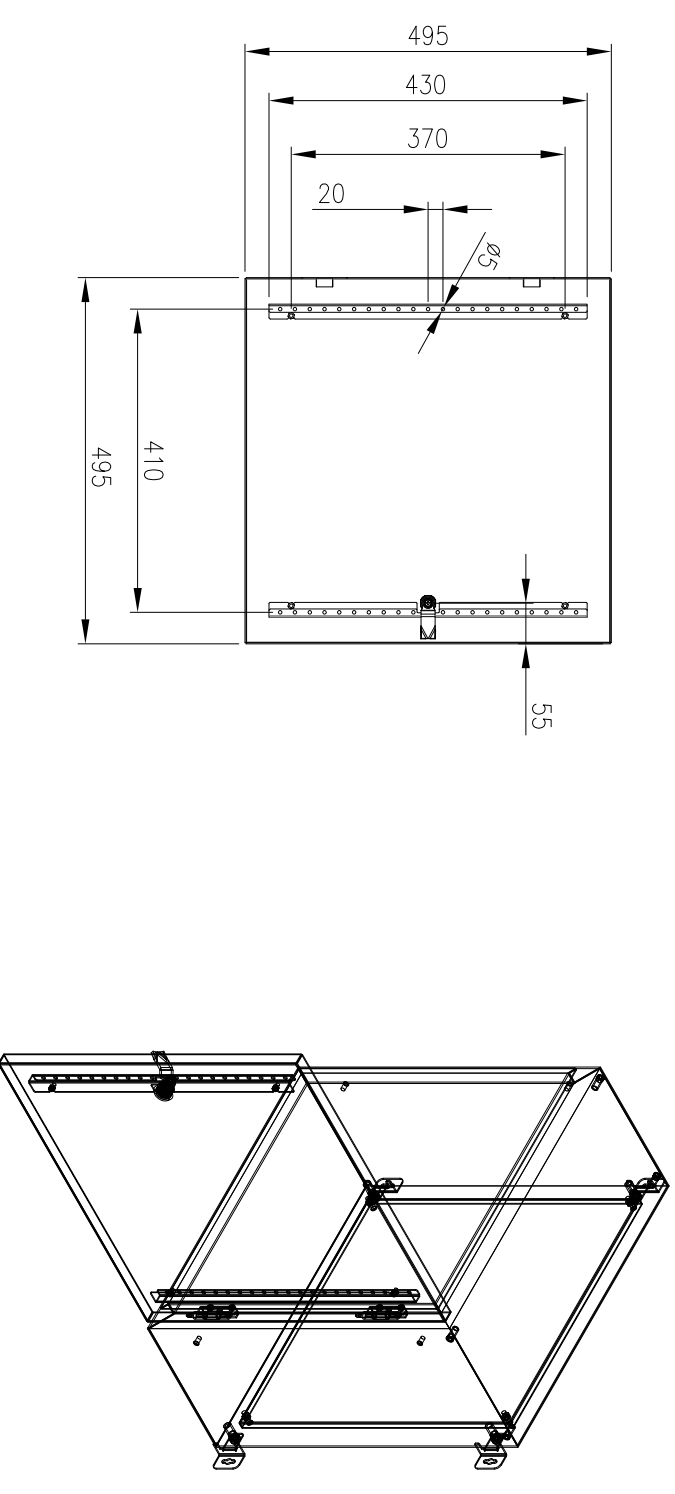
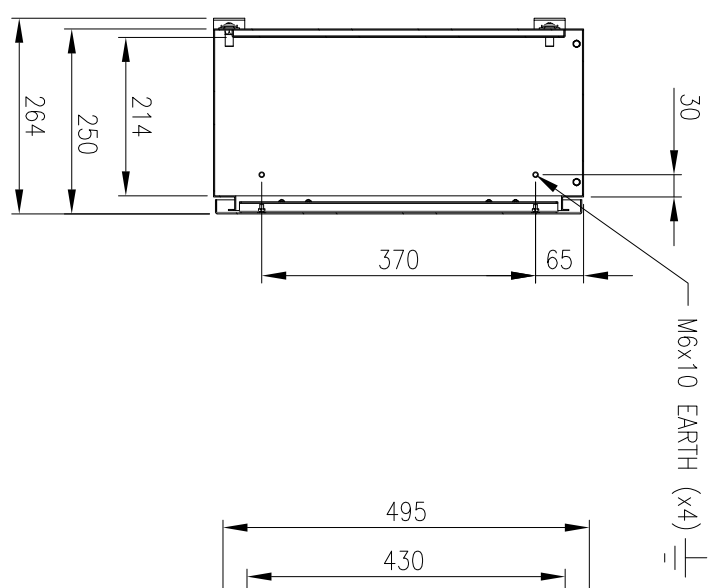

SECTION AY-AY

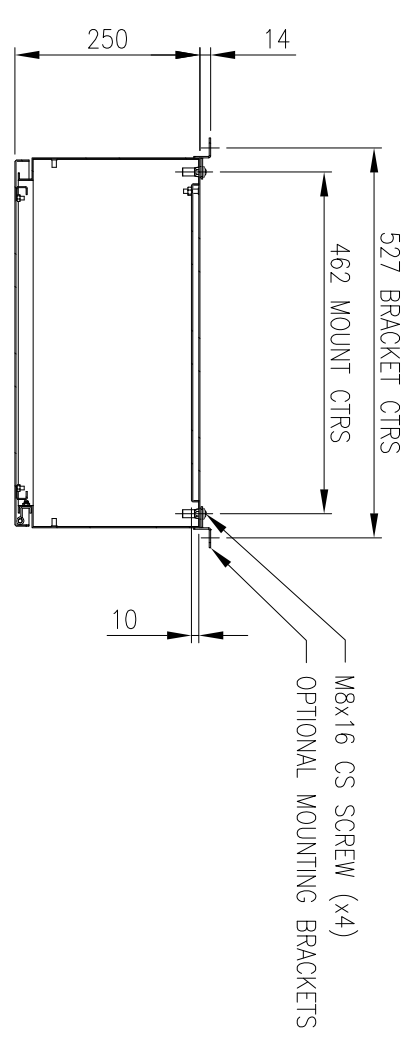

SECTION AW-AW

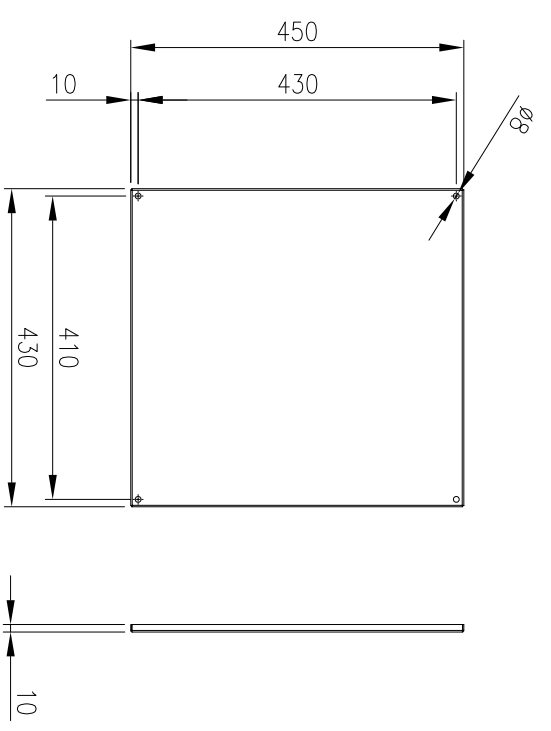

INSIDE DOOR VIEW

DEVICE MOUNTING PLATE

MATERIAL
 BODY: 1.5mm 316 STAINLESS STEEL
 DOOR: 1.5mm 316 STAINLESS STEEL
 DEVICE PLATE: 1.5mm GALV STEEL
 SEAL: POLYURETHANE

MASS: 16.5kg
PROTECTION: IP66 IK10, NEMA4x
STANDARD: IEC62208, IEC/EN/AS60529

© IP ENCLOSURES 2016.
 THIS DRAWING SHALL NOT BE COPIED OR REPRODUCED
 WITHOUT AUTHORISATION FROM IP ENCLOSURES.
 www.ipenclosures.com.au

Item	Quantity	TradeName, designation, material, dimension etc.	Article No./Reference	Scale
IP Enclosures				1:10
Designed by	Checked by	Approved by - date	Filename	Date
IP	IP	17/10/16	IP-SS9025-01	17/10/16
500X500X250 316SS ENCLOSURE				
IP-SS9025-01			2	1/1