

IP69K Terminal Box

IP-HTB1010

STAINLESS STEEL | IP66, IP69K

100H x 100W x 100D

IP69K Terminal Boxes are designed to prevent contamination and are suitable for the food & beverage, pharmaceutical and other industries.

Protection: Complies with IP66 IK08, IP69K, NEMA Type 1, 12, 4, 4x

Standard: EN/AS60529, ISO20653, UL508A, RoHS



Material:

- Body: 1.0mm to 1.2mm Grade 304 Stainless Steel
- Cover: 1.0mm to 1.2mm Grade 304 Stainless Steel
- Seal: Blue Silicone FDA compliant

Body: The body is fabricated using 1.0mm to 1.2mm Grade 304 Stainless Steel. It is designed to be completely smooth and without crevices and without concave angles to facilitate cleaning and avoid deposits. The body is designed to promote self draining for ease of hygienic cleaning.

Cover: The cover is fabricated using 1.0mm to 1.2mm Grade 304 Stainless Steel and includes a clip-in silicone seal.

Seal: Moulded blue replaceable silicone seal, suitable for temperatures ranging from -60°C to +135°C. FDA compliant for food production areas.

Mass: 0.68 kg

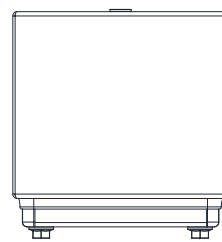

TOP VIEW

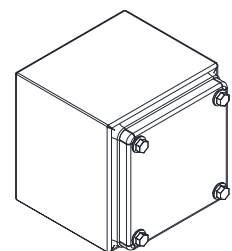

RIGHT SIDE VIEW

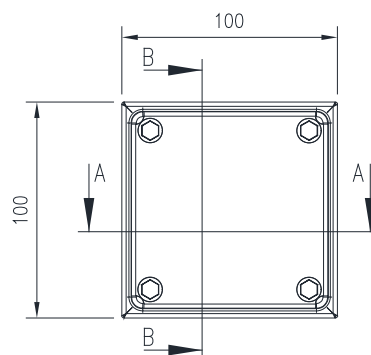

FRONT VIEW

