

Field Electrical Cabinet

IP-FE604030-KK

STEEL | SINGLE DOOR | IP66

600H x 400W x 300D

IP Enclosures range of outdoor electrical enclosures are suitable for general industrial applications.

Protection: IP66 IK10, NEMA 4
(Independent accredited test laboratory)

Standard: IEC62208, IEC/EN/AS60529 **CE**
(IEC/EN/AS61439 Compliant)

Material:

- Body: 1.5mm galvanised steel sheet
- Door: 1.5mm galvanised steel sheet
- Gland Plate: 1.5mm galvanised steel sheet
- Device Mounting Plate: 1.5mm galvanised steel sheet
- Seal: Polyurethane

Body: The robust monoblock body is fabricated using 1.5mm galvanised steel sheet. Flat face sealing surfaces are provided to increase seal life. Integral device plate mounts and M6 earth stud is provided.

Single Door: The robust surface mounted door is fabricated using 1.5mm galvanised steel sheet and incorporates concealed removable hinges with captive pins. The door is designed for a 110° opening. Each door contains integral cable management rail studs, M6 earth stud.

Seal: A high quality machine-applied full perimeter UL listed Polyurethane seal foamed in place (FIP) provides excellent sealing over a long life. Temperature resistance -40°C to 80°C (160°C short term loading).

Lock: 3 point lock with Pad lockable swing handle.

Device Mounting Plate: The device mounting plate is fabricated using 1.5mm galvanised steel sheet, pressed to provide additional strength and supplied pre-fitted into enclosure as standard.

Gland Plate: Gland plates are provided with gaskets and fasteners.

Surface Treatment: UL approved polyester powder-coated with a smooth gloss finish, 80-120 micron average thickness, providing excellent exterior durability and color retention. Colour: Karaka Green.

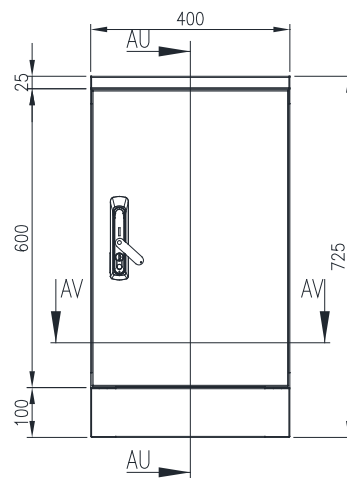

FRONT VIEW

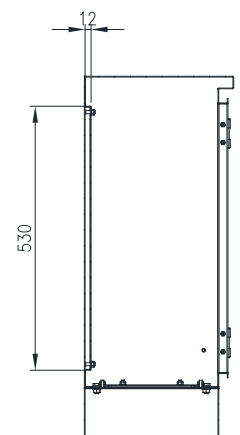

SECTION AU-AU

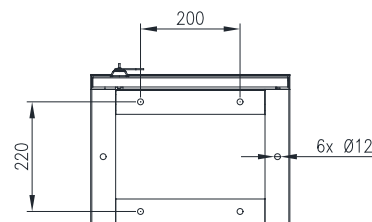

BOTTOM VIEW

