

# FCA 19" Field Cabinet

# IP-A16715062-0

ALUMINIUM | DOUBLE BAY 19" RACK | NON-VENTILATED 1675H x 1500W x 620D  
IP66 IK10 19" 60RU (2 x 30RU)

Marine Grade Aluminium Field Cabinets are designed to house sensitive data network and electrical equipment for a variety of heavy duty outdoor applications including road/traffic management and intelligent transport systems.

**Protection:** IP66 IK10

**Standards (& Conformities):** IEC/EN 60529, IEC/EN 62208, EIA-310-D, RoHS



**Rack Unit Size:** 60RU (2 x 30RU)

**Material:**

- Body and Plinth: 2.5mm Marine Grade Aluminium 5754-H111
- Doors: 2.5mm Marine Grade Aluminium 5754-H111
- 19" Data Rack Rails: 1.5mm galvanised steel sheet
- Gland Plate: 3.0mm aluminium
- Seal: Polyurethane

**Body:** The robust monoblock body is fabricated using 2.5mm marine grade aluminium. The body is fitted with rain hood/sunshield, plinth, vent hoods and 4x lifting eye bolts. Flat face sealing surfaces are provided to increase seal life. A 3.0mm aluminium split gland plate is also incorporated into the bottom face. Precision automated manufacturing equipment ensures accuracy and consistent high quality.

**Doors:** The front and rear doors are fabricated using 2.5mm marine grade aluminium and are designed to provide flush recessed mounting to prevent vandalism and unauthorised access. The doors incorporate concealed removable hinges with captive pins. They are designed for a 110° opening and are provided with heavy duty door stays.

**19" Data Rack Rails:** Front and rear 19" data rack rails are fabricated from 1.5mm galvanised steel sheet.

**Seals:** A high quality Polyurethane foamed in place (FIP) full perimeter door seals provide excellent sealing over a long life. Temperature resistance -40°C to 80°C.

**Locks:** Each door includes a 3 point locking system with key-lock swing handle. Optional locking including half euro keyed as required, restricted keys, Bilock and stainless steel padlockable.

**Gland Plate:** 3.0mm aluminium split gland plates are incorporated into the bottom of the enclosure for cable management.

**Surface Treatment:** UL approved AkzoNobel polyester powder coated with a smooth gloss finish, 80-120 micron average thickness, providing excellent exterior durability and colour retention. Colour RAL7035 Grey.

**Mass:** 108Kg.

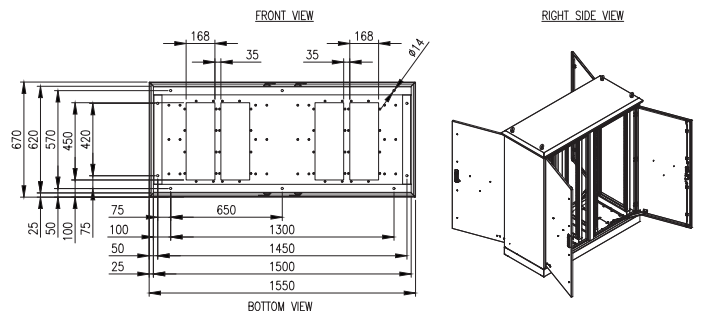
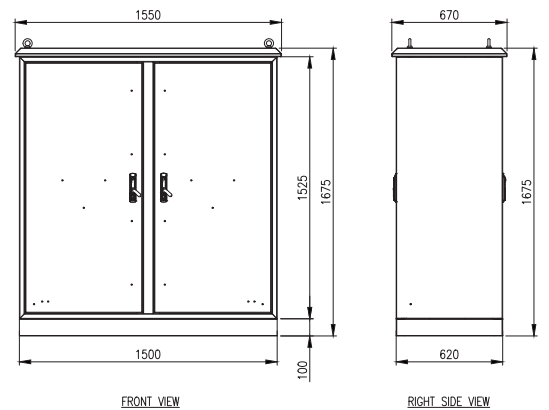

# FCA 19" Field Cabinet

# IP-A16715062-0

ALUMINIUM | DOUBLE BAY 19" RACK | NON-VENTILATED IP66 IK10 1675H x 1500W x 620D  
19" 60RU (2 x 30RU)

## ACCESSORIES:

Part Number	Description
IP-FCSHL7562	Light Duty Shelf to suit 750W x 620D Field Cabinet; 50Kg.
IP-FCSHH7562	Heavy Duty Shelf to suit 750W x 620D Field Cabinet; 250Kg.
IP-FCDRAWER620	Laptop Drawer to suit 750W x 620D Field Cabinet; 25Kg.
IP-M6SCREW-CAGENUT	M6 Cage Nut & Screw (Pack of 50)
IP-L014	3 Point Swing Handle Padlockable; Polyamide & Cast Alloy Coated Black
IP-L076	3 Point Swing Handle Padlockable; Cast Alloy Coated Black

## CERTIFICATES:

IEC 60529 Degrees of protection provided by enclosures: Certificate AB-0386-T 2009.33.02/00

IEC/EN 62208 Empty Enclosures for low-voltage switchgear and controlgear assemblies: Certificate 0366932-TSE-01/01

CE Certificate of Compliance: Certificate SZT-24 MA 33485-1

UKCA Certificate of Compliance: Certificate SZT-25 MA 38734-1

Products are manufactured to Quality, Safety and Environmental Standards.

**WARRANTY:** 5 years.