

IP55 Field Cabinet

IP-453522

STEEL | POLE MOUNT | IP55

450H x 350W x 225D

Pole-Mounted Field Cabinets are designed to house sensitive data network and electrical equipment for a variety of outdoor applications.

Protection: Complies with IP55 (Ventilated range)

Standard: IEC62208, IEC/EN/AS60529, EIA-310-D, RoHS 

Material:

- Body: 1.5mm galvanised steel sheet
- Door: 2.0mm galvanised steel sheet
- Enclosure Seal: Polyurethane

Body: The robust monoblock body is fabricated using 1.5mm galvanised steel sheet. Flat face sealing surfaces increase seal life. Pre-fitted blind nutserts are incorporated to accommodate pole mount bracket to eliminate drilling and retain IP rating. Integral device plate mounts and M6 earth stud are included. Fan/filter cutouts and hinged vent hoods are provided as standard.

Door: The front door is fabricated using 2.0mm galvanised steel sheet and is designed to provide flush recessed mounting to prevent vandalism and unauthorised access. The door incorporates concealed removable hinges with captive pins. It is hinged on the left side and is provided with a heavy duty door stay. An A4 plan pocket is provided.

Door Seals: Polyurethane foamed in place (FIP) full perimeter door seals provide excellent sealing over a long life. Temperature resistance: -40°C to 80°C.

Locks: Single-point locking system with key-lock swing handle. Optional locking including half euro keyed as required, restricted keys, Bilock, etc.

Surface Treatment: UL approved epoxy polyester powder coated with a smooth finish. 80-120 micron average thickness. Colour RAL7035 Light Grey. RAL6005 Moss Green is also available upon request.

Accessory: Optional Pole Mount Bracket (One-piece, full height). Optional Base: 600mm high base, flush to suit width and depth of field cabinet. Powder coated, colour RAL7035 Light Grey. RAL6005 Moss Green is also available upon request.

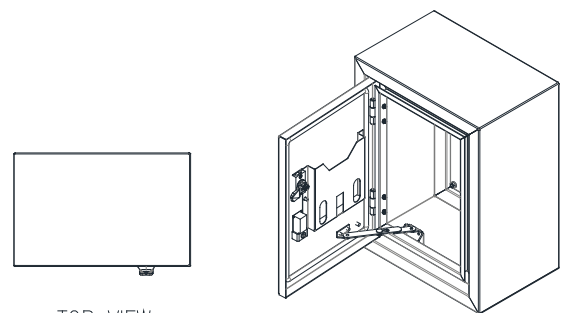

TOP VIEW

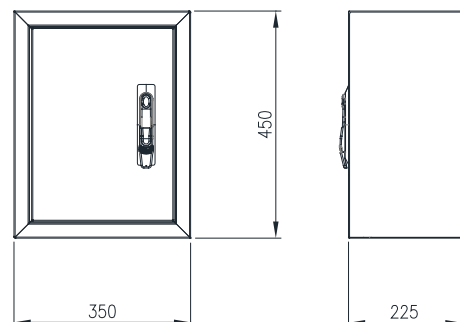

FRONT VIEW

SIDE VIEW