

IP55 19" Field Cabinet

IP-1079062-AC035-T33

STEEL | AIR-CONDITIONED 19" RACK | IP55

19"- 18RU 1075H x 900W x 620D

Air-Conditioned Field Cabinets are designed to house and cool equipment in harsh outdoor environments. They are rated to IP55 and designed to prevent unauthorised access while keeping contents cool by incorporating an internally-mounted air-conditioner. The air conditioner is housed in a separate compartment and is accessible via a recessed side door with louvered vent hood to enhance air flow. The cooled 19" rack compartment is rated to IP55 and is accessible via front and rear doors.

Protection: IP55 (Inside main 19" rack compartment)

Standard: IEC62208, IEC/EN/AS60529, EIA-310-D

Rack Unit Size: 18RU

Material:

- Body and Plinth: 2.0mm galvanised steel sheet
- Doors: 2.0mm galvanised steel sheet
- 19" Data Rack Rails: 1.5mm galvanised steel sheet
- Gland Plate: 3.0mm aluminium
- Enclosure Seal: Polyurethane

Body:

The robust monoblock body is fabricated using 2.0mm galvanised steel sheet. The body is fitted with rain hood/sunshield, plinth and 4 x lifting eye bolts. Flat face sealing surfaces are provided to increase seal life. A 3.0 mm galvanised steel split gland plate is also incorporated into the bottom face. A segmented compartment is provided to house the air-conditioner.

Doors: Front and rear doors are fabricated using 2.0mm galvanised steel sheet and are designed to provide flush recessed mounting to prevent vandalism and unauthorised access. The doors incorporate concealed removable hinges with captive pins. They are designed for a 110° opening and are provided with heavy duty door stays.

19" Data Rack Rails: Front and rear 19" data rack rails are fabricated from 1.5mm galvanised steel sheet.

Seal: A high quality full perimeter Polyurethane foamed in place (FIP) seal provides excellent sealing over a long life.

Locks: 3 point locking systems with key-lock swing handles.

Surface Treatment: UL approved epoxy polyester powder-coated with a textured finish. 80-120 micron average thickness. T33 Smoke Blue smooth finish.

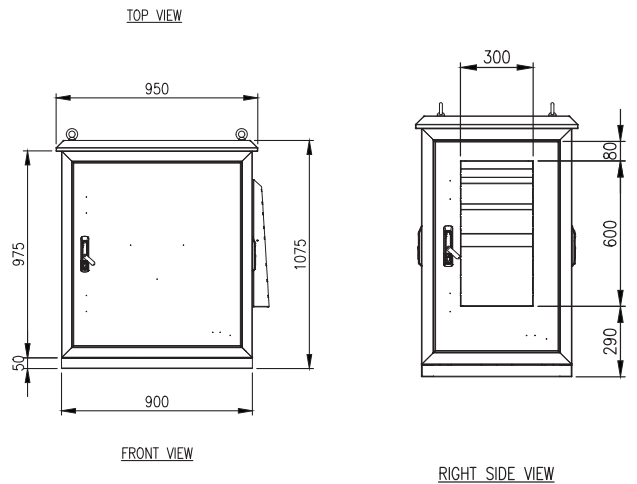
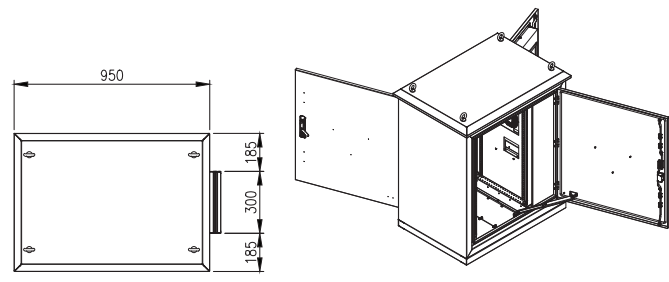

350 Watt

IP Enclosures air conditioners are designed for the cooling needs of electrical cabinets and have been designed for high efficiency and low maintenance. They are made in Italy and are SAA approved and certified for use in Australia.

Features	Unit	IP-ACOWM035
Power supply	V/Hz	230V/1ph/50-60
Dimensions HxWxD	mm	430x280x170
Cooling capacity EN814 A35A35	W	350/370
Cooling capacity EN814 A35A50	W	200/220
Air flow rate (free blow)		
inside	m³/h	350/390
outside	m³/h	600/625
Max current	A	1.8/1.9
Delayed fuse	A	4
Absorbed electric power EN814 A35A35	W	260/270
Absorbed electric power EN814 A35A50	W	280/300
Refrigerant (type/charge)	kg	R134a/300G
Maximum Pressure	Kpa	2400
Operating temperature (ambient)	°C	+20/+55
Operating temperature (enclosure)	°C	+20/+45
Temperature controller (factory set at 35°C)	-	Integrated mechanical thermostat
Compressor type	-	Rotative compressor
Noise level	dB(A)	60
Electrical connection	-	Three-pole connector
Protection degree EN60529/1 enclosure inside	-	IP54
Protection degree EN60529/1 ambient inside	-	IP34
Weight (with packaging)	kg	15(16)
Colour	-	RAL 7035
Conformity/Certifications	-	SAA, CE, AS/NZS60335.2.40:2019, AS/NZS60335.1:2020

