

RevNo	Revision note	Date	Signature	Checked
2	GENERAL REVISION	9/7/19	IP	IP

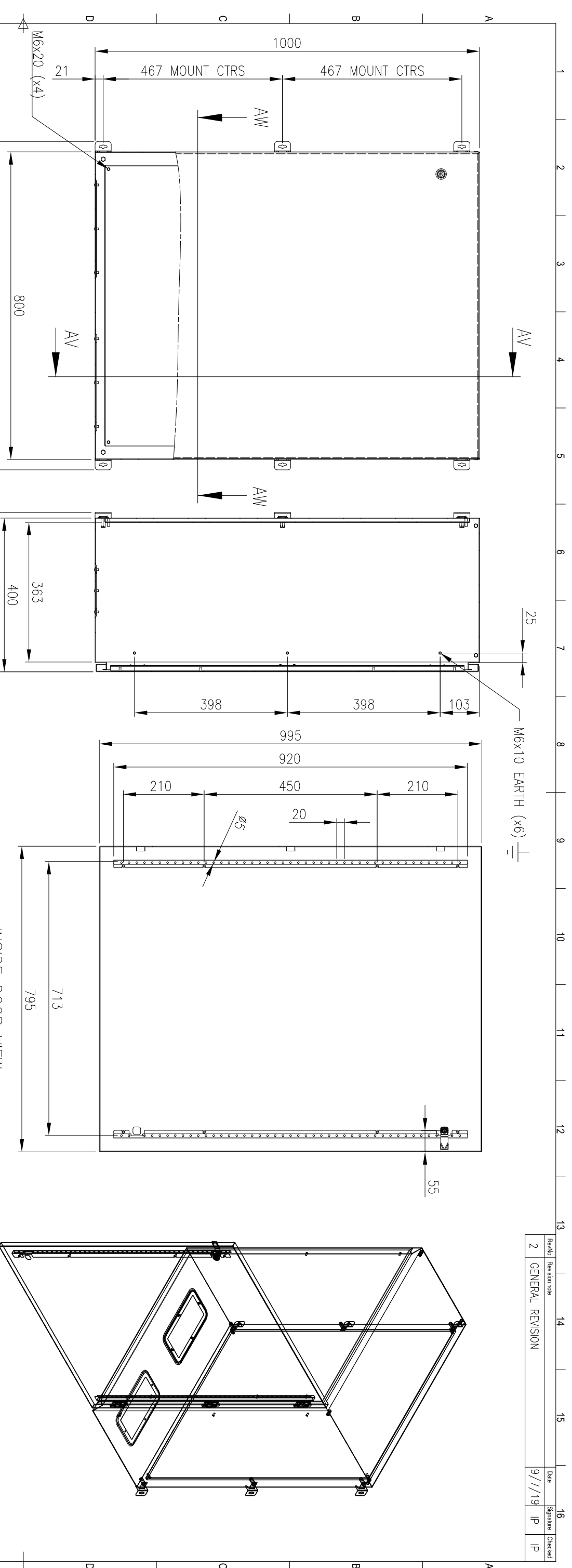

FRONT VIEW

SECTION AV-AV

INSIDE DOOR VIEW

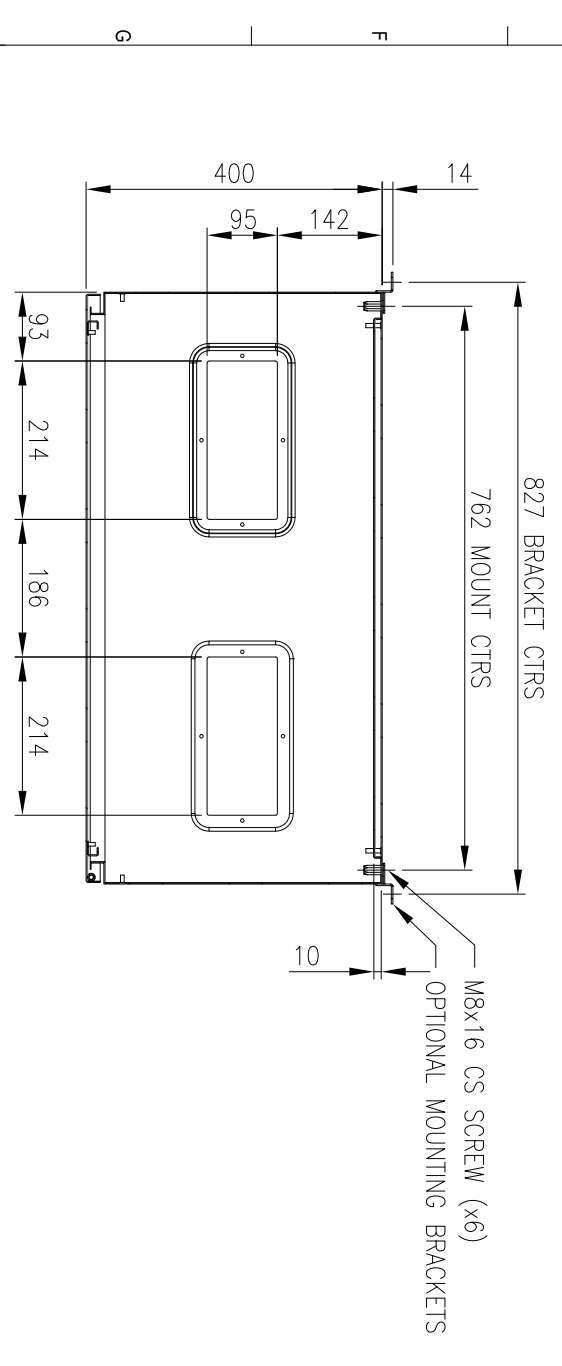

SECTION AW-AW

DEVICE MOUNTING PLATE

MATERIAL
 BODY: 1.5mm GALVANISED STEEL SHEET
 DOOR: 1.5mm GALVANISED STEEL SHEET
 DEVICE PLATE: 1.5mm GALVANISED STEEL SHEET
 SEAL: POLYURETHANE
 SURFACE TREATMENT: POWDER-COAT 80-120micron

MASS: 46.0kg
 PROTECTION: IP66 IK10, NEMA4
 STANDARD: IEC62208, IEC/EN/AS60529

© IP ENCLOSURES 2016.
 THIS DRAWING SHALL NOT BE COPIED OR REPRODUCED
 WITHOUT AUTHORISATION FROM IP ENCLOSURES.
 www.ipenclosures.com.au

Item#	Quantity	TradeName, designation, material, dimension etc.	Article No./Reference	Scale
IP				1:10
Designed by	Checked by	Approved by - date	Filename	Date
IP	IP	17/10/16	IP-1008040-01	17/10/16
1000x800x400 STEEL ENCLOSURE				
IP-1008040-01				
Edition				Sheet
2				1/1

